

V.A.G Service.

Workshop Manual Volkswagen Transporter 1980 ▶

Engine code	CS	JX	KY																
----------------	----	----	----	--	--	--	--	--	--	--	--	--	--	--	--	--	--	--	--

Diesel injection and glow plug system.

Edition January 1991



Service Department

Workshop Manual Volkswagen Transporter 1980 ►

Diesel injection and glow plug system

Edition 01.91

Supersedes Edition January 1985

The manual is divided into separate booklets which can be ordered individually and allocated on the shop floor as required.

This manual is valid for the Volkswagen Transporter with Diesel engine from the start of production (November 1980). It describes all the operations which require special instructions to ensure satisfactory work.

Layout of booklets

Each booklet has the contents listed according to Repair Groups to make it easy to find the information required.

The technical data follows the description of the repair operations. Each operation is preceded by an exploded view which also contains all the main repair instructions. This is supplemented, where necessary, by figures – which are referred to in the exploded view – giving details of the fitting positions of parts or showing special tools in use. If a definite sequence has to be followed when dismantling and assembling a component, the exploded view is followed by a description of the main steps of the work sequence. Any adjustments required are also explained.

Technical information should always be made available to all foremen and mechanics because compliance with the instructions given is essential to ensure vehicle roadworthiness and safety.

In addition, the normal safety precautions to be observed when working on motor vehicles are also applicable.

Workshop Bulletins

Workshop bulletins will be allocated to the individual booklets and should be filed at the back of the booklet concerned. To remind you that bulletins have been published, the manual pages should be marked by hand with the bulletin number as explained in the bulletin heading.

Fault finding

All instructions on Fault finding are filed in the appropriate binder.

Instructions on the elimination of current defects are given in the "Technical Service Handbook".

Contents

Contents according to Repair Groups

Rep.- Group	Contents	Page
23	Fuel system, Diesel injection	
	Servicing injection system	23-1
	● Removing and installing fuel filter (on vehicles ► 09.88)	23-5
	● Removing and installing fuel filter (on vehicles 09.88 ►)	23-7
	● Rules for cleanliness	23-9
	● Retrofitting fuel filter preheating	23-10
	● Removing electro-magnetic cut-off	23-18
	● Removing and installing fuel injection pump	23-19
	● Checking and adjusting injection pump timing	23-24
	● Checking valve timing	23-28
	● Stopping leaks from injection pump adapters	23-30
	● Adjusting idling speed and maximum engine speed (no load)	23-31
	● Removing and installing injectors	23-32
	● Servicing injectors	23-34
	● Injector parts	23-35
	● Checking injectors for condition of needle tip, breaking pressure and leakage	23-36
	Servicing fuel injection pump	23-39
	● Renewing injection pump throttle lever return spring	23-43
	● Renewing throttle lever bush in pump cover, pump cover gasket and O-ring for throttle lever shaft	23-46
	● Renewing volume adjustment screw O-ring	23-50
	● Renewing O-ring on injection timing cover	23-51
	● Renewing CSA shaft/cover O-ring	23-52

Rep.- Group	Contents	Page
28	Glow plug system	
	Checking glow plug system	28-1
	● Checking glow plug current draw with V.A.G 1315 A	28-1
	● Checking glow plugs	28-2
	● Glow plugs with burnt electrodes	28-4

Servicing injection system

- Secure all fuel hoses with hose clips.
- Checking valve timing – page 23–28.
- Setting engine speed – page 23–31.
- Note rules for cleanliness – page 23–9.
- Checking fuel system for leaks – see Assembly Group 4 cylinder Diesel engine, Mechanics.
- Always renew sealing rings.
- Servicing injection pump – page 23–39.

1 – 45 Nm

2 – Injection pump sprocket

- Removing – see removing injection pump, page 23–19

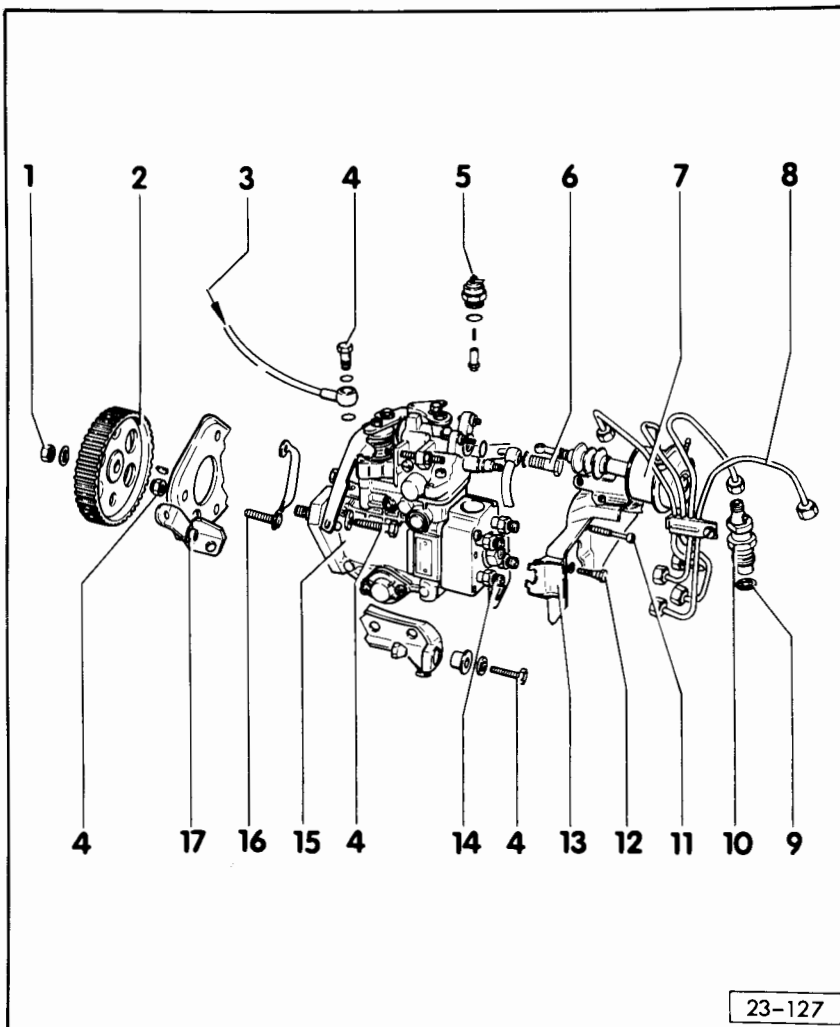

23–1

3 – From fuel filter

- Removing and installing fuel filter – page 23–5

4 – 25 Nm

5 – Electro-magnetic cut-off, 40 Nm

- Must click when ignition is switched on and off
- Removing on turbo-engine – page 23–18

6 – 25 Nm

- Banjo bolt for return pipe
- is marked "OUT".

7 – BPE valve

- For boost pressure enrichment
- Turbocharged engines only
- Checking – see checking charge pressure, Assembly Group 4 cylinder Diesel engine, Mechanics
- If damaged renew complete with injection pump

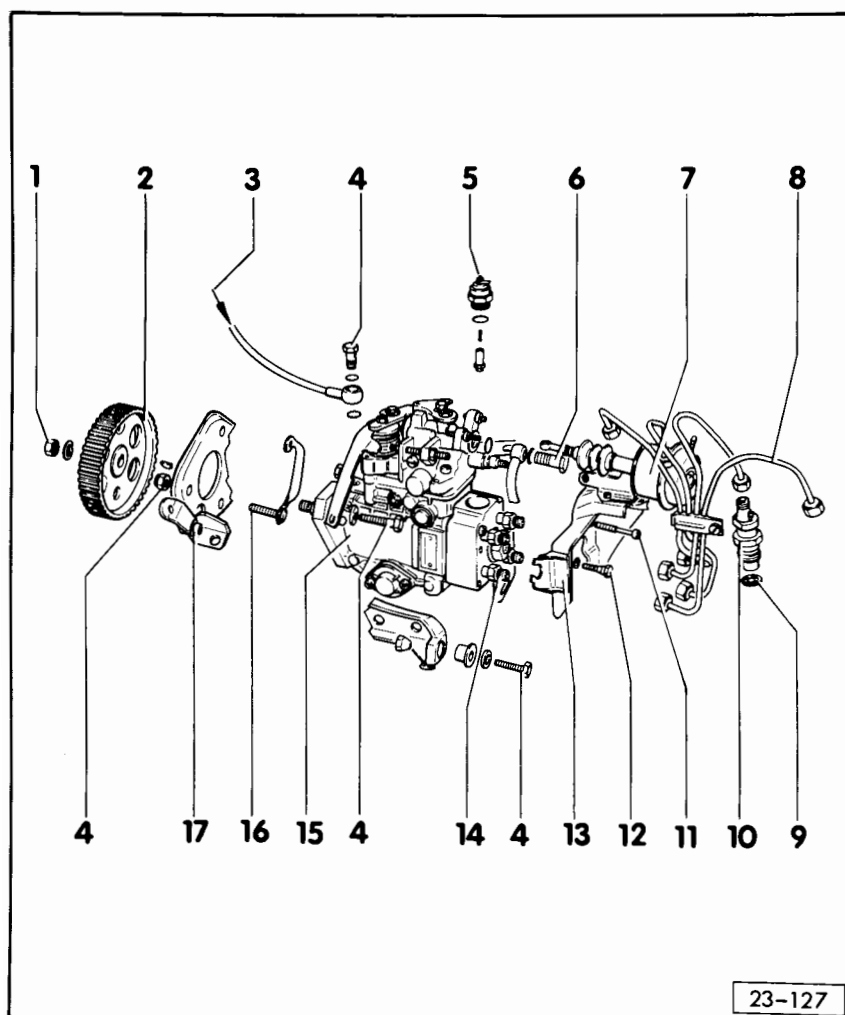

23–2

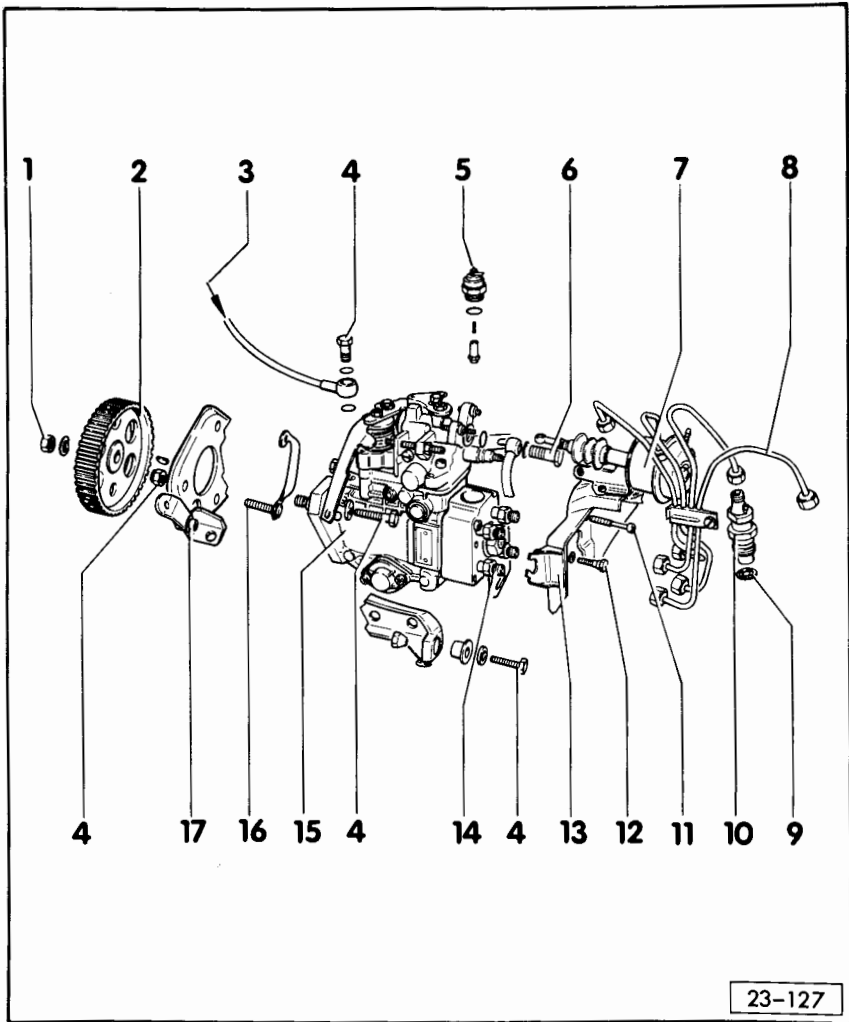

- 8 – Injector pipes, 25 Nm**
 - Use 3035 to remove
 - Always remove complete pipe set
 - Do not alter shape
- 9 – Heat protecting seal**
 - Renew
 - Fitting position – page 23–34
- 10 – Injector, 70 Nm**
 - Removing and installing – page 23–32
 - Servicing – page 23–34
- 11 – 12 Nm**
- 12 – 15 Nm**
 - Tighten when leaking, up to max. 25 Nm permissible
- 13 – Console**
 - Turbocharged engine only
 - Removing – see removing electromagnetic cut-off, page 23–18

23–3

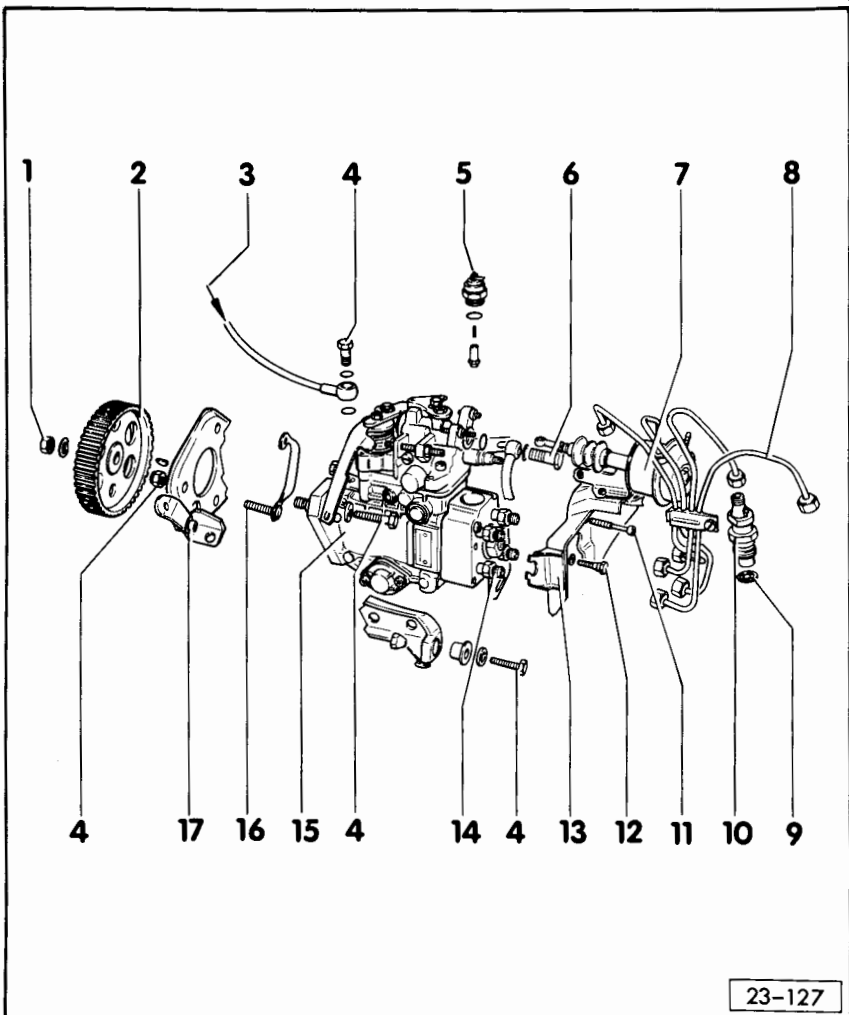

- 14 – Connection**
 - Removing, installing and sealing – page 23–30
- 15 – Injection pump**
 - Removing and installing – page 23–19
 - Adjusting pump timing – page 23–24
 - With the exception of the repairs described on page 23–39 if a pump is defective it must be renewed as an injection pump tester is required in order to repair.
- 16 – Bracket**
- 17 – Console**

23–4

Removing and installing fuel filter

(on vehicles ► 09.88)

Notes:

- Secure all fuel hoses with hose clips.
- Note rules for cleanliness – page 23–9.

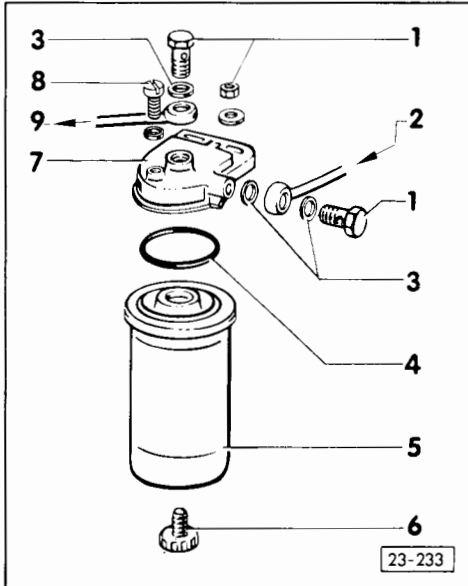

◀ 1 – 25 Nm

2 – From fuel tank

3 – Sealing ring

- Renew if damaged

4 – O-ring

- Renew
- Coat with diesel before installing filter.

23–5

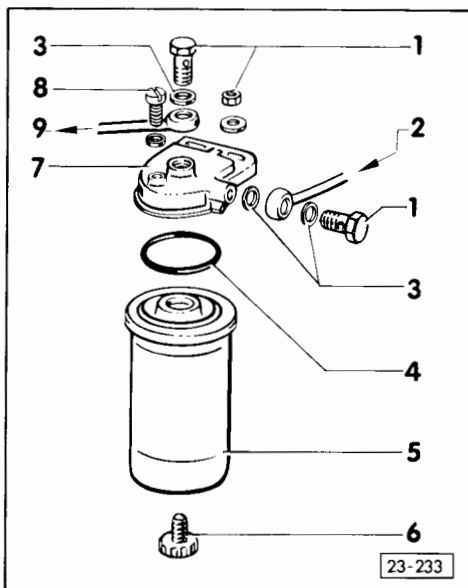

◀ 5 – Fuel filter

- Loosen with oil filter spanner e. g. Matra W 167
- Tighten hand tight
- 09.88 ► with fuel filter preheating – page 23–7
- Retrofitting fuel filter preheating – page 23-10

6 – Water drain plug

- Loosen and drain off approx. 100 cm³ fluid

7 – Fuel filter – upper part

8 – Vent screw

- Loosen to drain water

9 – To injection pump

23–6

Removing and installing fuel filter

(on vehicles 09.88 ►)

Notes:

- Secure all fuel hoses with hose clips.
- Note rules for cleanliness – page 23–9.

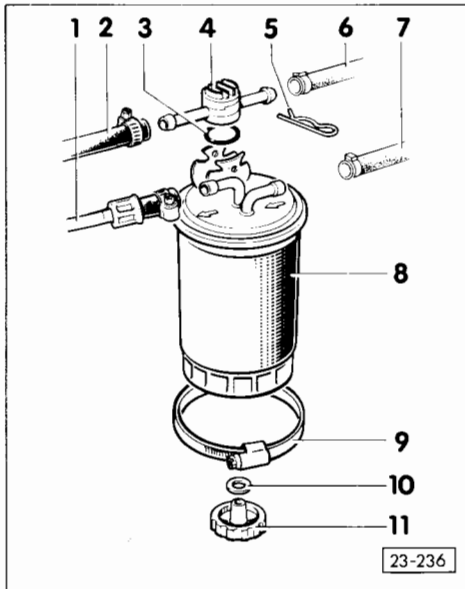

- ◀ **1 – Supply pipe**
- Transparent, to the injection pump
- 2 – Return pipe**
- From the injection pump
- 3 – O-ring**
- Renew
- 4 – Control valve**
- Fitting position: Arrow points to fuel tank
 - Below +15° C:
Flow to filter open
 - Above +31° C:
Flow to filter closed
- 5 – Retaining clip**

23–7

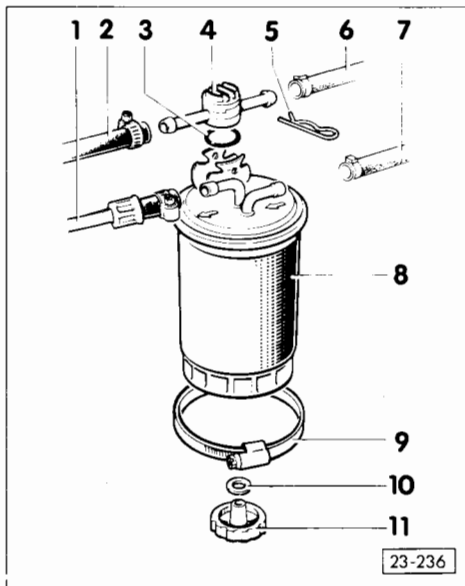

- ◀ **6 – Return pipe**
- To fuel tank
- 7 – Supply pipe**
- From fuel tank
- 8 – Fuel filter**
- Direction of flow is marked with arrows
 - When renewing filter, release retaining clip –5– and remove control valve –4– with fuel pipes connected
- 9 – Securing strap**
- 10 – Gasket**
- Only renew if damaged
- 11 – Water drain plug**
- Loosen and drain approx. 100 cm³ fluid
 - To bleed release retaining clip and remove control valve with fuel pipes connected

23–8

Rules for cleanliness

Attention!

When working on the injection system, the following five rules for cleanliness should be adhered to:

- 1 – Thoroughly clean connections and the adjacent area **before disconnecting**.
- 2 – Place parts on a **clean** surface and cover them with foil or paper.
Do not use fluffy cloths!
- 3 – Opened components should be carefully covered or sealed if a repair cannot be completed quickly.
- 4 – Use **clean** parts only.
 - Unpack parts immediately before they are to be installed.
 - Do not use parts which have been lying about unpacked (e. g. in tool box etc.)
- 5 – When system is open:
 - Do not use compressed air if avoidable.
 - Avoid moving vehicle where possible.

Also ensure that the Diesel fuel does not get onto the coolant hoses. If it does, the hoses must be cleaned immediately. Hoses which have already been affected by Diesel fuel must be renewed.

23-9

Retrofitting fuel filter preheating

(on vehicles ► 09.88)

Vehicles without “syncro”

- Remove existing filter with upper part and bracket.
- install new bracket in place of old one.
- Fit O-ring, install control valve as shown and secure with retaining clip –5–.

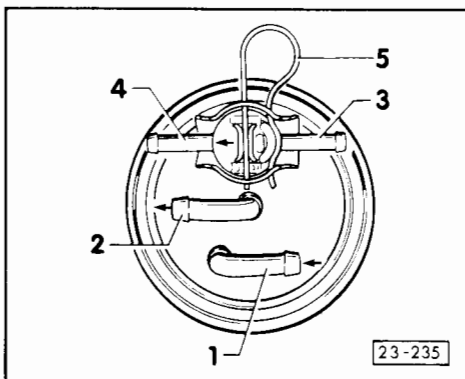

- ◀ 1 – Supply from fuel tank
- 2 – Supply to injection pump
- 3 – Return from injection pump
- 4 – Return to fuel tank (marked with arrow)
- 5 – Retaining clip

23-10

Note:

If the control valve is damaged during installation (fractures), the engine will start after installation but further fuel will not be drawn up (see transparent pipe). In this case install a new control valve.

- Install fuel filter and connect fuel hoses as follows.

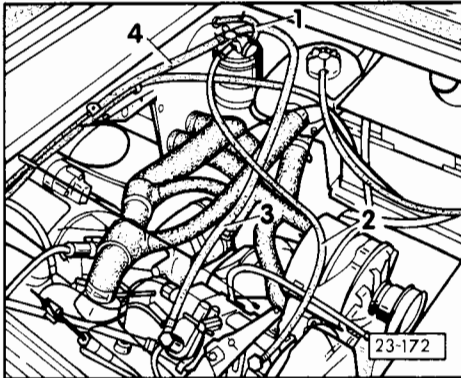

- ◀ ● **Fuel pipe –1–**
Supply fuel tank/filter
 - Remove banjo union connector from existing plastic pipe by cutting plastic pipe.
 - Push new fuel hose $7 \times 3 \times 120$ mm over the plastic pipe and install as shown.
- **Fuel pipe –2–**
Supply fuel filter/injection pump
 - Remove existing transparent pipe.
 - Saw off banjo union ring on the filter end, connection remains in the fuel pipe.

23–11

- Remove burrs from connection and clean pipe.
- Push hose $7 \times 3 \times 60$ mm, over the transparent pipe and secure with a hose clip in the area of the connection still in the pipe.
- Reinstall transparent pipe as shown.

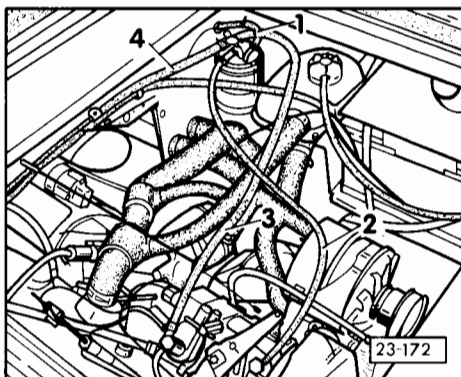

- ◀ ● **Fuel pipe –3–**
Return injection pump/control valve
 - Cut existing return pipe behind the banjo union connector.
 - Cut open pipe on banjo union connector and remove.
 - Install new return hose $5 \times 3 \times 800$ mm as shown.
- **Fuel pipe –4–**
Return control valve/fuel tank
 - Push new hose $7 \times 3 \times 300$ mm onto the shortened existing fuel pipe.

23–12

- Route return pipe as shown and connect to the side of the control valve marked with an arrow.

Notes:

- Secure all connecting points with hose clips.
- Secure all newly routed fuel hoses with hose ties, so that they cannot come into contact with moving parts.
- The installation of the non-return valve in the fuel return pipe is not necessary.

23-13

“Syncro” vehicles

Installing non-return valve

- Cut return hose 60 mm in front of the connector on fuel tank.

Note:

If the fuel tank is full clamp-off return hose in front of the connector.

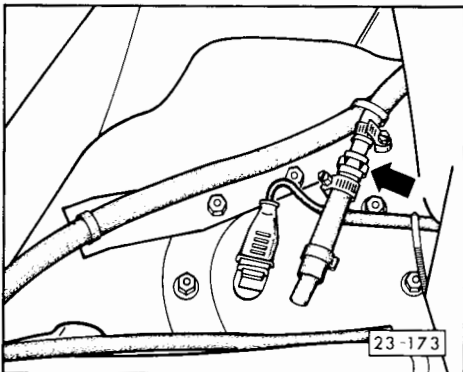

- ◀ – Install non-return valve as shown – arrow – in return pipe.

Attention!

Arrows must point to fuel tank.

23-14

Installing new filter

- Remove existing filter with upper part and bracket.
- Fit new bracket in place of the old one.
- Fit O-ring, install control valve as shown and secure with retaining clip –5–.

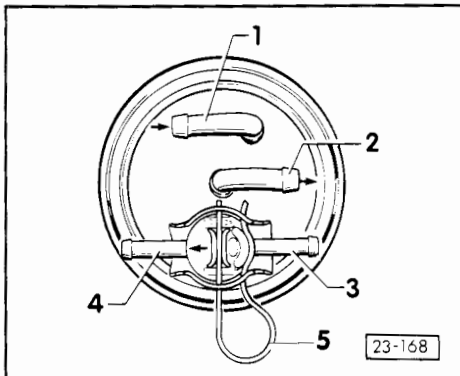

- ◀ 1 – Supply from fuel tank
- 2 – Supply to injection pump
- 3 – Return from the injection pump
- 4 – Return to fuel tank (marked with arrow)
- 5 – Retaining clip

Note:

If the control valve is damaged during installation (fractures), the engine will start after installation but further fuel will not be drawn up (see transparent pipe). In this case install a new control valve.

23–15

- Install fuel filter and connect fuel hoses as follows.

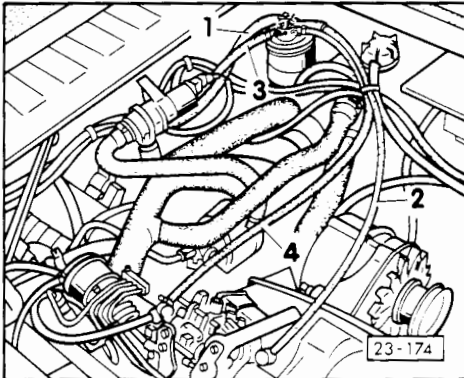

- ◀ ● **Fuel hose –1–**
Supply fuel tank/filter
 - Shorten existing hose 60 mm by cutting off from the banjo connection end and install as shown.
- **Fuel hose –2–**
Supply fuel filter/injection pump
 - Remove existing transparent pipe.
 - Saw off banjo union ring on filter end, connection remains in the fuel pipe.
 - Remove burrs from connection and clean pipe.
 - Push hose 7 x 3 x 60 mm over the transparent pipe and secure with a hose clip in the area of the connection still in the pipe.
 - Reinstall transparent pipe as shown.

23–16

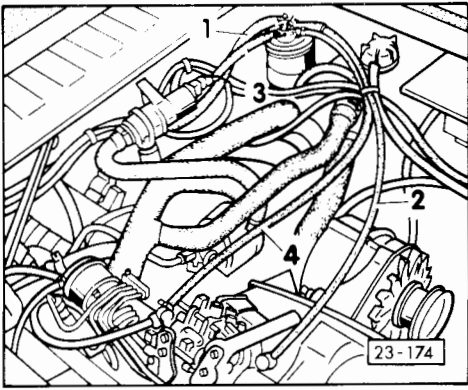

- ◀ ● **Fuel hose –3–**
Return control valve/fuel tank
 - Disconnect existing return hose from banjo union connector at injection pump, pull into engine compartment as far as possible and connect to the side of the control valve marked with an arrow.
- **Fuel hose –4–**
Return injection pump/control valve
 - Install new return hose 5 × 3 × 700 mm as shown between injection pump and control valve.

Notes:

- Secure all connecting points with hose clips.
- Secure all newly routed fuel hoses with hose ties, so that they cannot come into contact with moving parts.

23–17

Removing electro-magnetic cut-off

Turbocharged engine

- Remove injector pipes.
- Disconnect throttle cable and cold start accelerator (CSA) cable.
- Remove console complete with BPE valve.

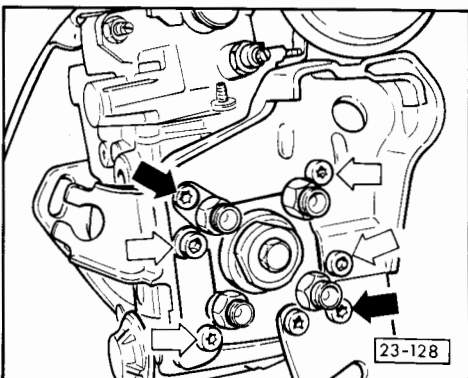

- Attention!**

 - To remove the console, the four bolts – white arrows – must be removed.
 - Under no circumstances may the other two securing bolts for the FIP head – black arrows – be slackened off.
 - Slackening off all the securing bolts leads to tilting of the head and fracturing of the distributor piston.
- Remove electro-magnetic cut-off.

23–18

Removing and installing fuel injection pump

Removing

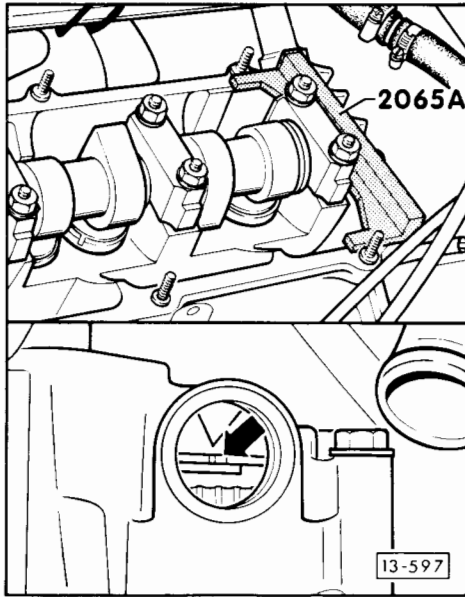

- ◀ – Set engine to TDC No. 1 cylinder – arrow – and fix camshaft with setting bar – align setting bar as follows:

With setting bar in position, turn camshaft slightly until one end of bar touches cylinder head. Measure gap at other end with feelers. Take half of measurement and insert feeler of this thickness between bar and cylinder head. Now turn camshaft so that bar rests on feeler. Insert second feeler of same thickness between other end of bar and cylinder head.

- Take toothed belt off camshaft sprocket and injection pump sprocket.
- Remove nut holding injection pump sprocket.

23–19

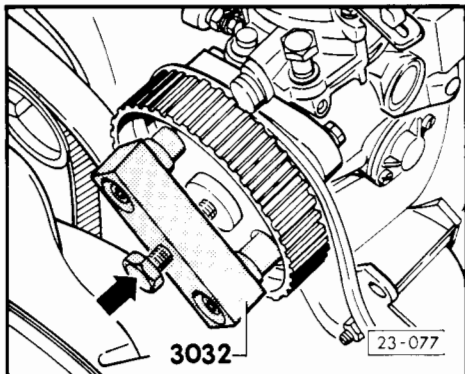

- ◀ – Loosen puller legs and fit puller.
- Align legs to the injection pump sprocket holes and tighten.
- Tension injection pump sprocket with puller.
- Loosen injection pump sprocket from taper by tapping lightly on puller spindle – arrow – (when doing this hold sprocket, to prevent it falling down).
- Disconnect all fuel pipes from the pump and cover openings with a clean cloth.

Note:

Use slotted ring spanner 3035 to loosen pipe unions.

- Disconnect stop control cable.
- Disconnect accelerator and cold start accelerator cable.

23–20

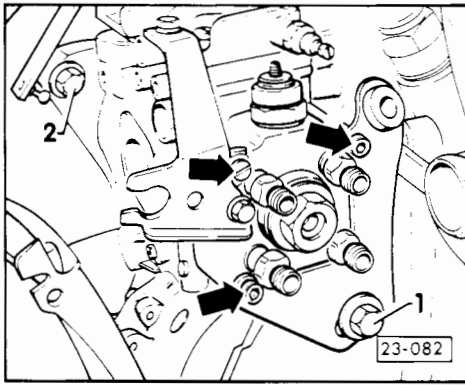

- ◀ – Remove bolts from console –2– (3 off).
- Remove bolt from rear support –1–.

Attention!

On no account should the screws holding the pump head be loosened – arrows –. Loosening these screws allows head to move and causes breakage of distributor piston.

Installing

- ◀ – Install pump and align marks on pump and console. Install pump sprocket.

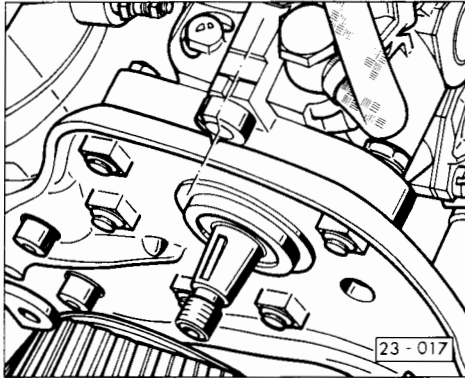

23–21

Tightening torques:

Pump mounting bolts:	25 Nm
Fuel pipes:	25 Nm
Pump sprocket:	45 Nm

Attention!

Do not interchange the feed and return pipe banjo union bolts. The inside dia. of banjo bolt for return pipe is smaller and head is marked "OUT".

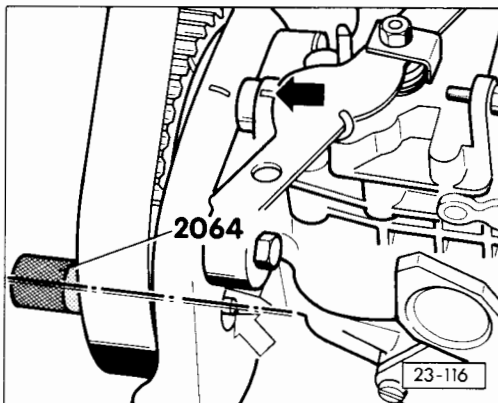

- ◀ – Turn pump sprocket until marks on sprocket and console are in line – arrow –.
- Lock pump sprocket with pin 2064 – white arrow –.
- Loosen camshaft sprocket bolt 1/2 a turn and knock sprocket off taper by tapping with rubber hammer.

23–22

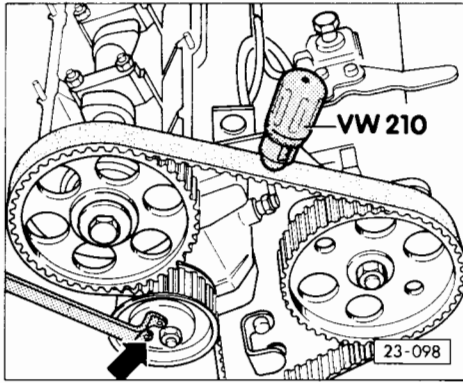

- Check that TDC mark on clutch is aligned with reference mark.
 - Install toothed belt and remove locking pin from pump sprocket.
 - ◀ - Tension toothed belt (turn tensioner to right with pin wrench e. g. Matra V 159 – arrow –).
- Scale figure: 12 . . . 13
measured between camshaft sprocket and injection pump sprocket.
- Tighten camshaft sprocket to 45 Nm.
 - Remove setting bar.
 - Turn crankshaft two full turns in engine D.O.R. and check toothed belt tension again.
 - Check pump timing – page 23–24.
 - Check and adjust idling speed and maximum engine speed – page 23–31.

23–23

Checking and adjusting injection pump timing

Test and adjustment conditions

- Toothed belt tension OK.
 - Cold start accelerator cable must not be pulled out (injection pump operating lever in 0 position).
- Set engine to TDC No. 1 cylinder.

Engine installed:

- ◀ - Rotate engine until TDC mark on the clutch and the boss on the bell housing and the marks on injection pump sprocket and console are aligned.

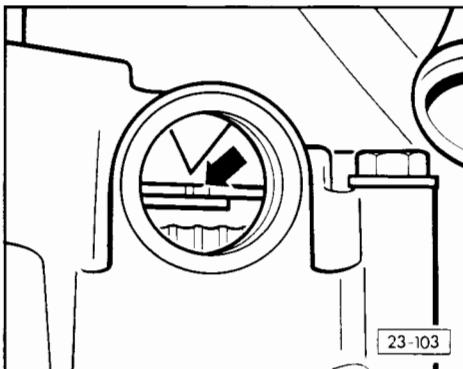

23–24

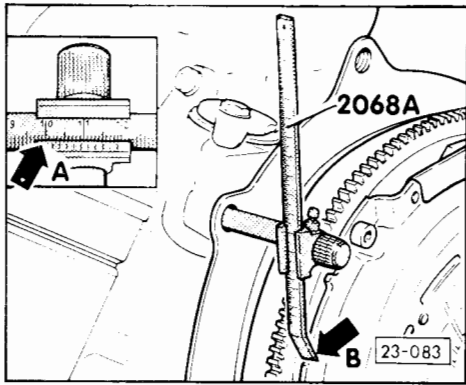

Engine removed:

- ◀ – Set adjusting gauge to 100 mm. The reference point is the line on the left of the vernier scale – arrow A –.

Attention!

Remove spring washer from adjusting gauge securing screw and change screw round.

- Fit adjusting gauge as shown.
- Turn crankshaft until the TDC mark on the clutch is aligned with tip of adjusting gauge – arrow B – and the marks on injection pump sprocket and console are aligned.

23–25

Checking and adjusting

- Unscrew plug from injection pump cover.

Attention!

- Always use a new washer when installing plug.
- Tightening torque 15 Nm.
- If leakage occurs plug can be retightened to a maximum of 25 Nm.

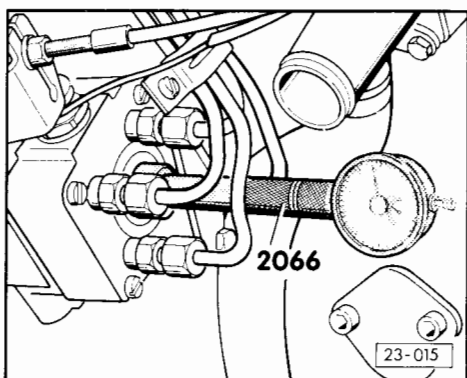

- ◀ – Install adapter and small dial gauge (0 . . . 3.0 mm range) in place of plug and preload gauge to about 2.5 mm.
- Turn engine slowly anti-clockwise (opposite to normal rotation) until dial gauge needle stops moving.
- Zero gauge with approx. 1 mm preload.
- Turn engine clockwise (normal rotation) until TDC mark on clutch is aligned with reference mark.

23–26

- Read off point of injection on dial gauge:
 Test figure = 0.83 . . . 0.97 mm stroke
 Adjusting figure = 0.90 ± 0.02 mm stroke

Attention!

If the test figure is within the specified tolerance it is not necessary to reset pump timing.

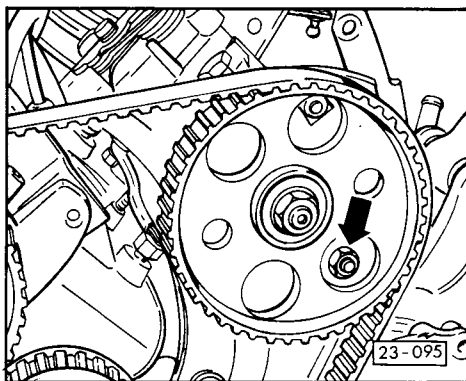

- To adjust, loosen the two upper screws on console and screw securing the rear support.
- ◀ - The lower screw on console is loosened from front through hole in pump sprocket – arrow –.
- Set pump commencement of injection by turning the injection pump to obtain adjusting figure.
- Tighten securing bolts to 25 Nm.

23-27

Checking valve timing

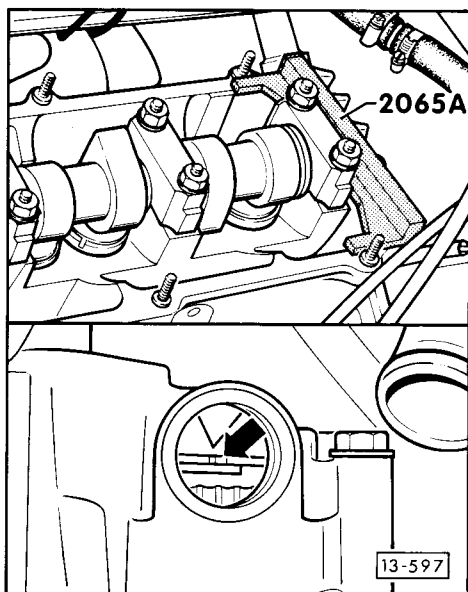

- Remove cylinder head cover.
- Check toothed belt tension.
- ◀ - Set engine to TDC No. 1 cylinder – arrow –.
- Insert setting bar in recess on camshaft.
 If the setting bar cannot be inserted, adjust valve timing as follows.
- Turn crankshaft so that setting bar can be inserted, and align setting bar as follows:
 With setting bar in position, turn camshaft slightly so that one end of setting bar touches cylinder head. Measure gap at other end with feelers. Take half of measurement and insert feeler of this thickness between setting bar and cylinder head. Now turn camshaft so that setting bar rests on feeler. Insert second feeler of same thickness between other end of setting bar and cylinder head.

23-28

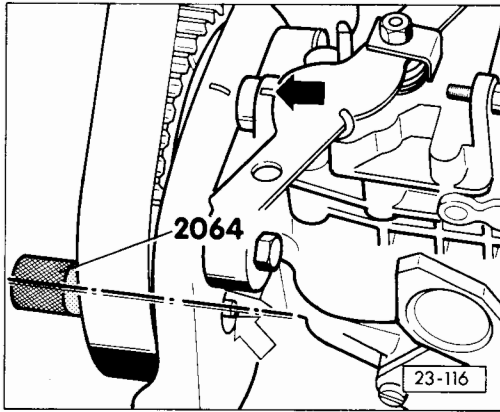

- Remove toothed belt guard.
- Loosen bolt securing camshaft sprocket half a turn.
- Knock camshaft sprocket off taper on camshaft by tapping it with a rubber hammer.
- ◀ - Turn injection pump sprocket until marks on gear and console are in line – black arrow –.
- Lock pump sprocket with pin – white arrow –.
- Turn crankshaft until TDC mark on clutch is aligned with boss on bell housing – see Fig. 13-597, page 23–28.
- Remove locking pin.
- Tension toothed belt and tighten camshaft sprocket bolt to 45 Nm.
- Remove setting bar.
- Check injection pump timing – page 23–24.

23–29

Stopping leaks from injection pump adapters

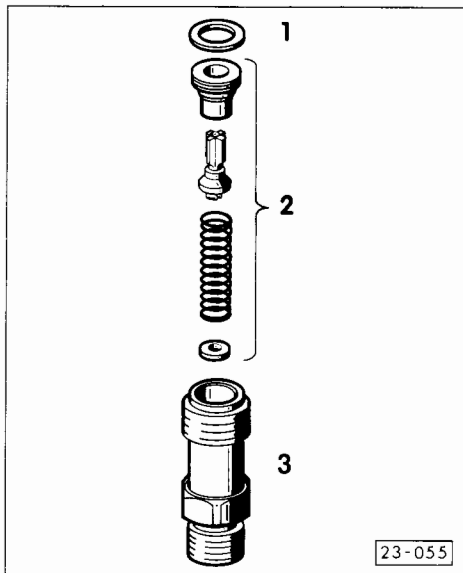

- ◀ 1 – Sealing ring
- 2 – Pressure valve
- 3 – Adapter

- Loosen pipe union.
- Tighten adapter to 45 Nm.
- Tighten pipe union to 25 Nm.

If this does not stop the leak, install new adapters and washers.

Attention!

When fitting new adapters do not interchange the pressure valves.

Adjusting idling speed and maximum engine speed (no load)

- Engine oil temperature min. 60° C.
- Cold start accelerator cable must be pulled out.
- Electrical consumers switched off.
- The engine speed can be checked with ignition tester VW 1367 via the TDC sender or with the adapter VW 1324 in conjunction with the speed, dwell and ignition tester VW 1267.

Idling speed

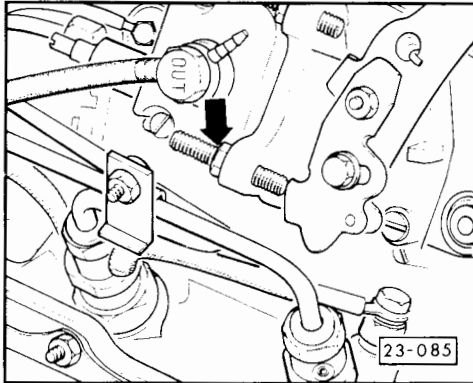

- ◀ – Set speed with idling adjustment screw – arrow –.

Engine code CS, JX:
820 ± 50 rpm

Engine code KY:
900 ± 30 rpm

- Lock adjusting screw.

23–31

Maximum engine speed (no load)

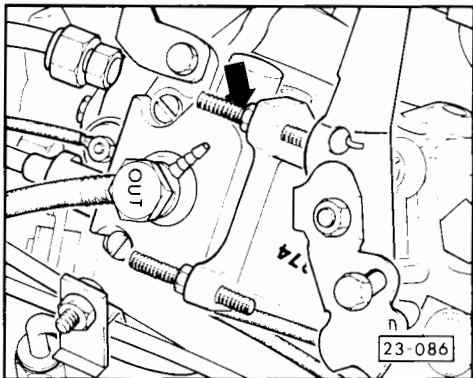

- ◀ – Open throttle fully and set engine speed with adjusting screw – arrow –.

Engine code CS: 4800 ± 50 rpm

Engine code JX: 5100 ± 100 rpm

Engine code KY: 5100 ± 50 rpm

- Lock adjusting screw.

Removing and installing injectors

Note:

Faulty injectors can cause the following conditions:

- Misfiring
- Knocking in one or more cylinders
- Overheating
- Loss of power
- Excessive smoky black exhaust
- High fuel consumption
- Excessive blue smoke when starting from cold.

23–32

Faulty injectors can be located by loosening the pipe union on each injector in turn with the engine running at a fast idle. If the engine speed does not change after loosening a pipe union, this indicates that that injector is faulty.

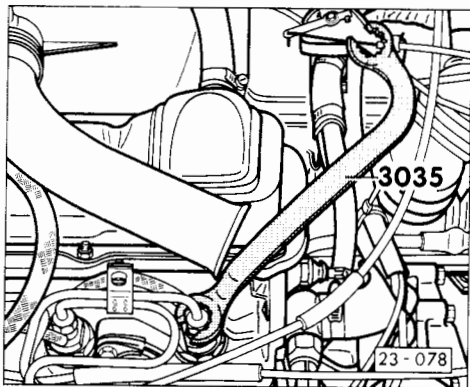

Removing

- ◀ – Remove injector pipes with slotted ring spanner.
- Remove injectors with 27 mm socket.

Attention!

Always remove pipe set complete. Do not alter shape.

23–33

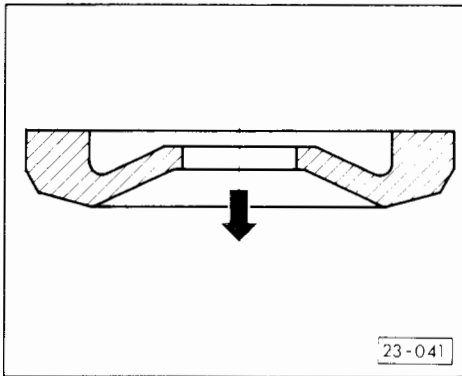

Installing

Attention!

Always install new heat protection seals between cylinder head and injectors.

- ◀ Position of heat protection seal:
Arrow points towards cylinder head.

Tightening torque:

Injector pipes: 25 Nm
Injectors: 70 Nm

Servicing injectors

- ◀ – Clamp upper part in vice and loosen hexagon.
- To prevent parts from falling out, clamp lower part in vice and dismantle.
- When dismantling, keep all individual parts together and do not interchange with parts from other injectors.

Tightening torque for upper and lower parts:
70 Nm.

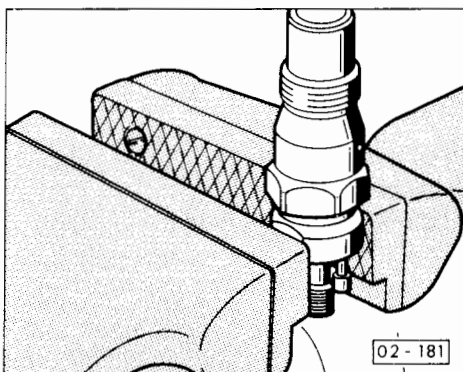

23–34

Injector parts

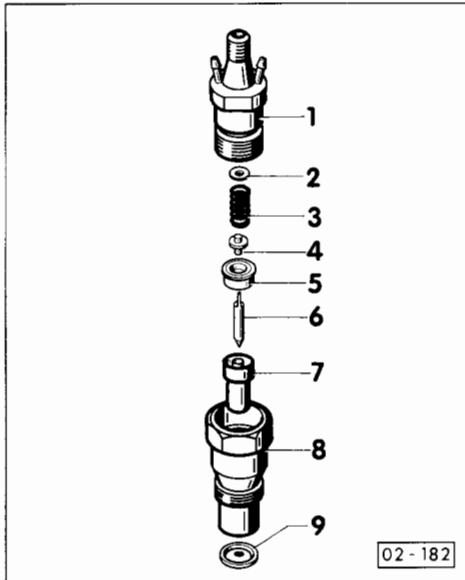

- ◀ 1 – Injector upper part
- 2 – Shim
- 3 – Spring
- 4 – Thrust pin
- 5 – Nozzle holder
- 6 – Needle
- 7 – Nozzle
- 8 – Injector lower part
- 9 – Heat protecting seal

23-35

Checking injectors for condition of needle tip, breaking pressure and leakage

Attention!

When testing injectors, take care not to expose the hands to the fuel spray as the fuel under high pressure can penetrate the skin causing serious injuries.

Checking injector needle tip

(visual check)

If the injector needle tip is damaged e. g. broken-off or bent, renew injector or nozzle with needle.

◀ Breaking pressure test

Gauge valve open:

- Move pump lever down slowly. Watch pressure at which injector breaks off, if necessary adjust by changing the shims.

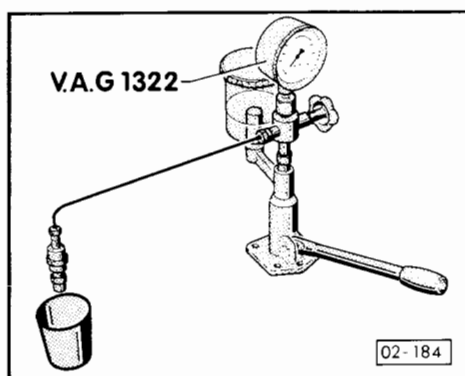

23-36

Specified pressures:

- NA Diesel
new injectors: 130 . . . 138 bar
wear limit: 120 bar
- Turbo-Diesel
new injectors: 155 . . . 163 bar
wear limit: 140 bar

Thicker shim = increases pressure

Thinner shim = decreases pressure

- Increasing shim thickness by 0.05 mm increases the pressure by about 5.0 bar.

Shims are available in thickness from 1.00 . . . 1.95 mm in 0.05 mm steps. The box – 3065 – should be used to store the shims.

Note:

When servicing used injectors, set the breaking pressure to the figure for new injectors.

23–37

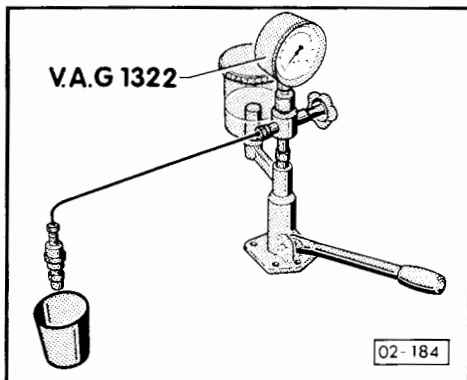

Leakage test

◀ Gauge tap open:

- Press pump lever down slowly and hold a pressure of about 110 bar for 10 seconds. No fuel should leak from the nozzle tip.

23–38

Servicing fuel injection pump

The following sealing operations can be carried out on the fuel injection pump:

- Note rules for cleanliness – page 23–9.
- Renewing injection pump throttle lever return spring –26– – page 23–43.
- Renewing throttle lever bush –23–, throttle lever O-ring –22– and gasket between pump cover and housing –19– – page 23–46.
- Renewing volume adjustment screw O-ring –1– – page 23–50.
- Renewing injection timing cover O-ring –17– – page 23–51.
- Renewing CSA shaft/cover O-ring –10/12– – page 23–52.

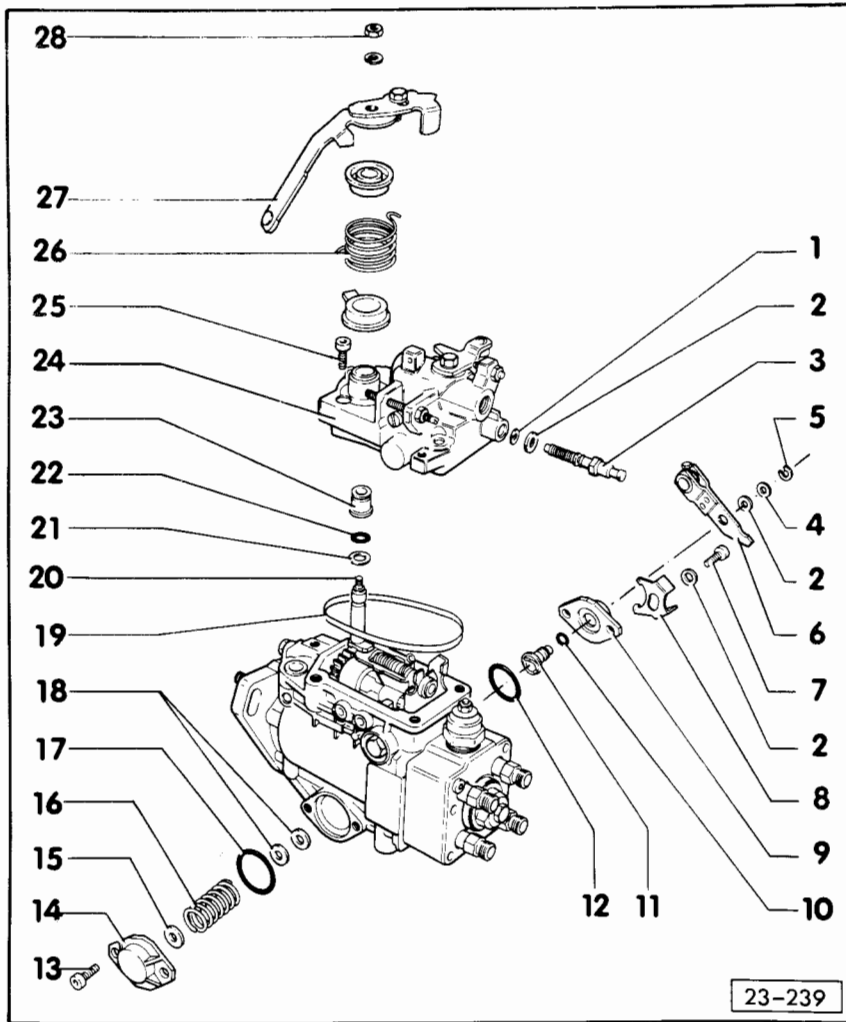

23–39

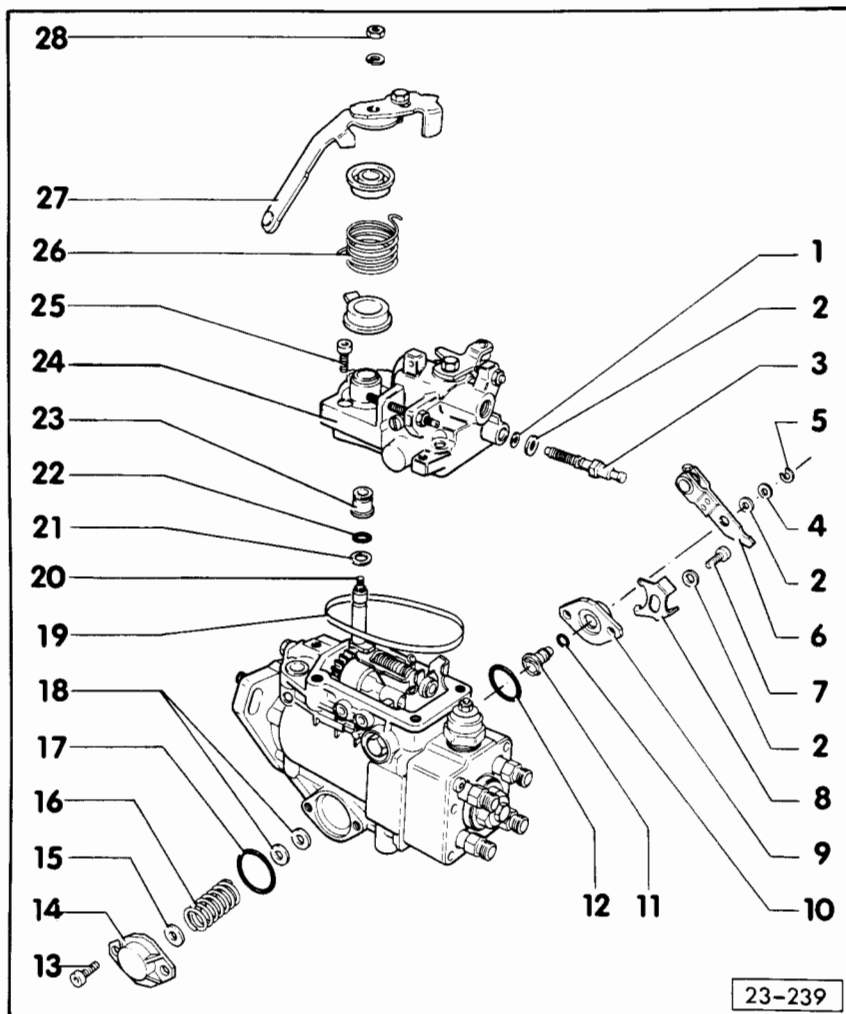

- 1 – O-ring
 - Renew – page 23–50
- 2 – Washer
- 3 – Volume adjusting screw
 - Mark position
- 4 – Spring washer
- 5 – Circlip or nut
- 6 – CSA lever
 - Mark position
- 7 – 10 Nm
- 8 – Stop plate
 - Adjusting – page 23–52
- 9 – CSA cover
- 10 – O-ring
 - Renew – page 23–52

23–40

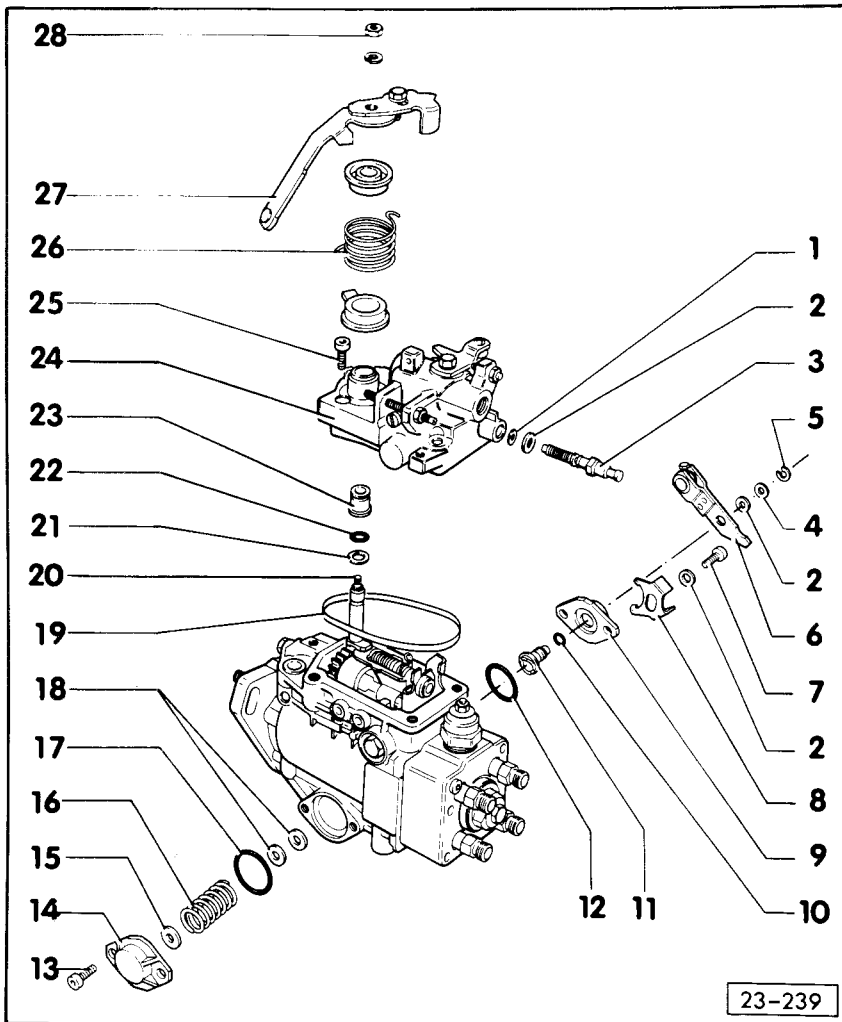

- 11 – CSA shaft
- 12 – O-ring
 - Renew – page 23–52
- 13 – 10 Nm
- 14 – Injection timing cover
- 15 – Shims
- 16 – Injection timing spring
- 17 – O-ring
 - Renew – page 23–51
- 18 – Shims
- 19 – Gasket
 - Renew – page 23–46
- 20 – Throttle lever shaft
 - Push out with screwdriver handle
- 21 – Thrust washer

23–41

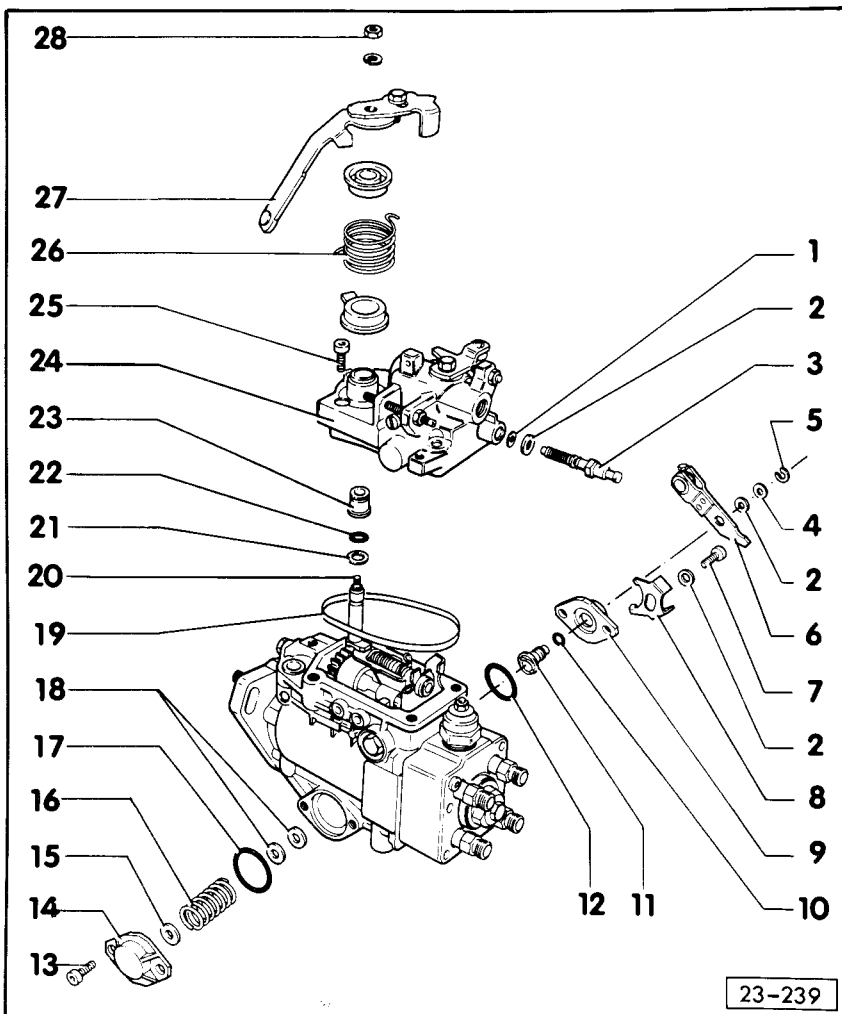

- 22 – O-ring
 - Renew
- 23 – Bush
 - Renew – page 23–46
- 24 – Pump cover
- 25 – 10 Nm
- 26 – Return spring
 - Renewing – page 23–43
- 27 – Throttle lever
 - Mark installation position
- 28 – 10 Nm

23–42

Renewing injection pump throttle lever return spring

Note:

The items indicated without illustration refer to the exploded view 23–239 on page 23–39.

Attention!

When renewing the return spring ensure that the throttle lever –27– position is not altered in relation to the throttle lever shaft –20–.

Removing

- Check that idling speed and maximum speed are as specified and if necessary, adjust.
- Disconnect throttle cable.
- ◀ – Mark position of throttle lever in relation to throttle lever shaft.

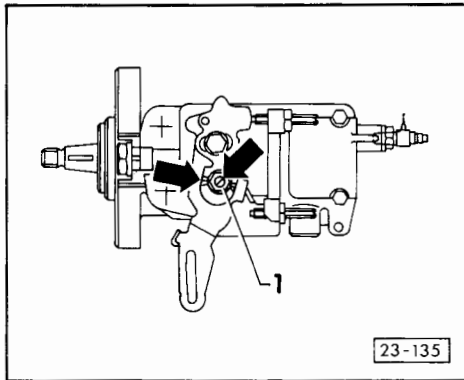

23–43

Note:

In some cases etched marking – arrows – are to be found on the throttle lever and throttle lever shaft.

- Disconnect return spring.
- Slacken off securing nut –1–, remove throttle lever and return spring.

Installing

- Place new spring in position.
- Fit throttle lever in marked position and tighten securing nut to 10 Nm.
- Attach return spring (using wire hook).
- Check, and if necessary, adjust idling speed.

23–44

Note:

Provided the idling speed does not deviate more than about 200 rpm from the specification after fitting a new spring, the throttle lever installation position need not be altered.

- If the throttle lever is moved one tooth in an anti-clockwise direction to the shaft, the engine will race at approx. 4000 rpm at the idling position.
- If the lever is moved one tooth in a clockwise direction, the engine will run at a considerably lower idling speed – approx. 500 rpm – or it will not start at all unless the throttle is opened and it will stall during idling.
In such cases, correct the throttle lever position.

23–45

Renewing throttle lever bush in pump cover, pump cover gasket and O-ring for throttle lever shaft

Notes:

- The items indicated without illustration refer to the exploded view 23–239, page 23-39.
- Remove return spring and throttle lever, see page 23–43.

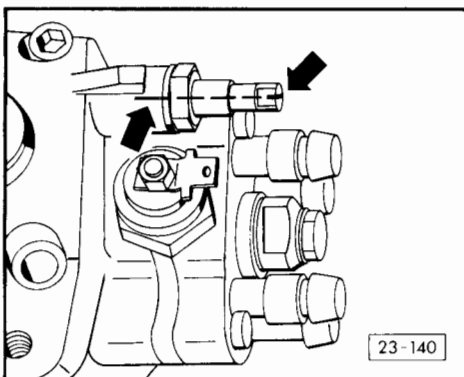

- ◀ – Mark position of volume adjustment screw in relation to pump cover, e. g. screw slot to pump cover – arrows –.
- Slacken off locking nut, rotate against the locking sleeve and screw volume adjustment screw out of pump cover.

23–46

Attention!

The slightest amount of maladjustment of the volume adjustment screw can cause soot build-up and/or loss of engine power. For this reason, it is important that the same position is adhered to on reassembly. On no account may the volume adjustment screw be screwed in past the original position.

- Remove the 4 screws securing the cover. If the idling speed adjustment screw is concealing one of the screws, the adjustment screw must also be removed.
- Lift pump cover -24-, press throttle lever shaft -20- towards inside of cover (e. g. with screwdriver handle) when taking the cover off.
- ◀ - Take off pump cover and press out bush -23- as shown.
- Clean pump cover.

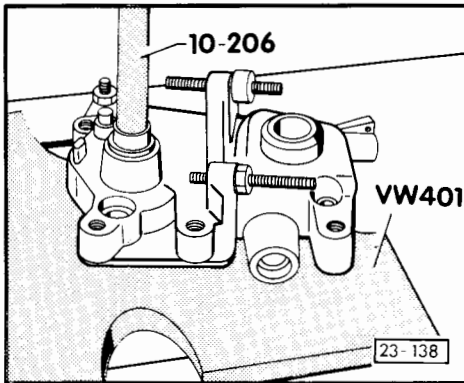

23-47

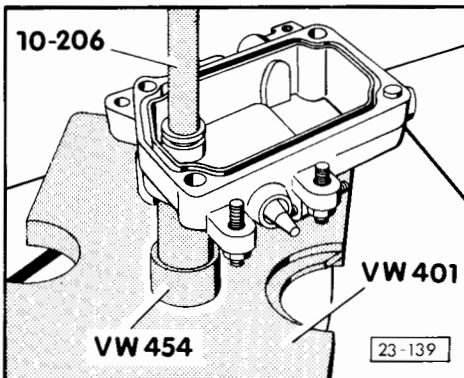

- ◀ - Coat outside surface of new bush with D6 and press into cover as shown, up as far as collar.
- Very carefully remove surplus D6.

Note:

Depending on the type of pump, various types of bush are available. Select correct type of bush by comparison with old bush.

- Install new O-ring -22- for throttle lever.
- Install new pump cover gasket -19-. (The sealing ring is prevented from falling out, when fitting the cover, by small protrusions around the outside of the ring).
- Coat throttle lever shaft and O-ring with diesel fuel and push into bush, then place pump cover in position.

Attention!

Ensure that the throttle lever thrust washer -21- is in position.

23-48

- Tighten pump cover.
- Screw in volume adjustment screw –3– with a new O-ring as shown.
- Install return spring and throttle lever, see page 23–43.
- Run engine until warm and check idling and maximum speeds.
- Check exhaust opacity with combustion tester V.A.G 1500, see Fault Finding Programme Diesel engine No. 2 “Excessive black exhaust smoke”.

23–49

Renewing volume adjustment screw O-ring

Note:

- The items referred to without illustration, refer to the exploded view 23–239, on page 23–39.

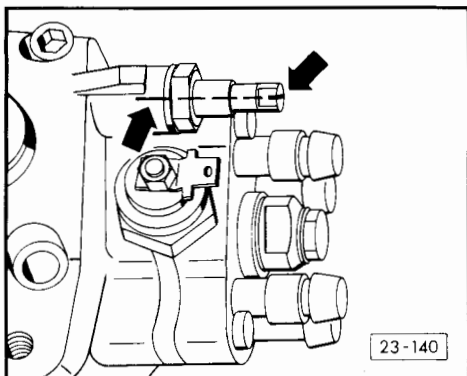

- ◀ – Mark position of volume adjustment screw in relation to pump cover, e. g. screw slot to pump cover – arrows –.
- Slacken off locking nut, rotate against locking sleeve and screw volume adjustment screw out of pump cover.

Attention!

The slightest amount of maladjustment of the volume adjustment screw can cause soot built-up and/or loss of engine power. For this reason it is important that the same position is adhered to on reassembly. On no account may the volume adjustment screw be screwed in past the original position.

23–50

- Renew O-ring -1-.
- Screw in volume adjustment screw as shown.
- Run engine until warm and check idling and maximum speeds.
- Check exhaust opacity with combustion tester V.A.G 1500, see Fault Finding Programme Diesel engine No. 2, "Excessive black exhaust smoke".

Renewing O-ring on injection timing cover

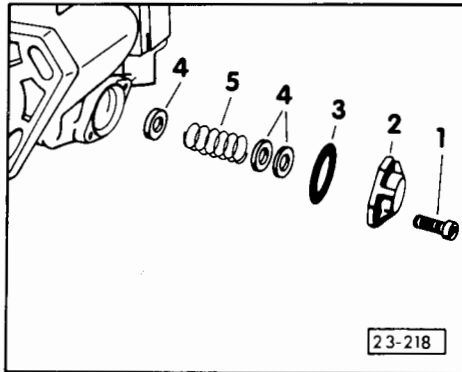

- Place a clean cloth underneath fuel injection pump.
- ◀ - Remove cover screws -1- with normal type angled key for Torx socket head screws, e. g. Hazet 2115-T30.
- Remove and clean cover -2-.
- Renew O-ring -3- and install cover with original shims -4-.

23-51

Renewing CSA shaft/cover O-ring

Note:

For items referred to without illustration, refer to the exploded view 23-239 - page 23-39.

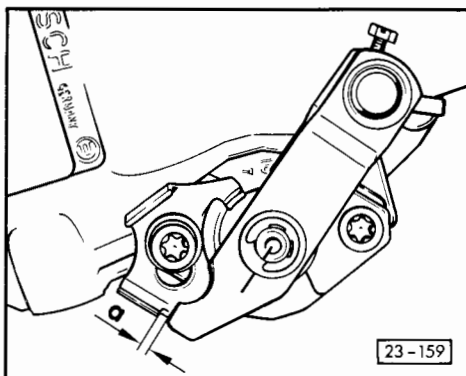

- Remove FIP.
- ◀ - Mark position of CSA lever in relation to shaft by scribing a line on the lever and shaft.
- Remove circlip.
- Remove CSA lever.
- Remove cover screws -7- and take off cover -9-.
- Pull CSA shaft -11- out of cover.
- Renew O-rings -10/12- for shaft/cover.
- Press CSA shaft into cover.
- Install cover.

23-52

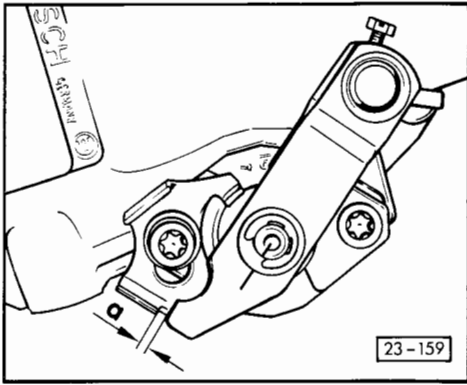

- Install CSA lever in position as marked and secure.
- ◀ – Adjust CSA lever stop plate as follows:
 - Loosen stop plate securing screws half of one turn.
 - Move CSA lever by hand in advance direction to start of injection advance stroke (noticeable resistance).
 - Adjust stop plate with lever in this position to 1 mm clearance –a– and tighten securing screw.
- Install FIP.

Checking glow plug system

Test prerequisites:

- Engine cold.
- Battery voltage OK.
- Voltage at glow plugs. If there is no voltage, see Fault Finding with V.A.G. 1466.

Checking glow plug current draw with V.A.G 1315A

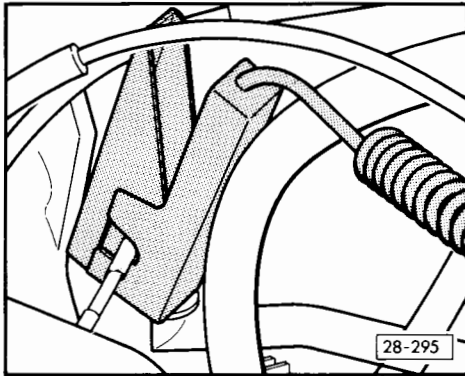

- Connect tester to current supply.
- ◀ – Place glow plug wire in current clamp.
- Press button for current measurement with current clamp.
- Pull wire off engine temperature sender.
- Turn ignition key to heating for maximum 15 seconds.

28-1

- Read off current draw.
Current draw approx. 48 A: Glow plugs OK.
Current draw less than 48 A, see checking glow plugs.

Checking glow plugs

Current draw should stabilize at about 12 A per glow plug. If glow plugs give a current draw of about

- 36 A = one glow plug defective
- 24 A = two glow plugs defective
- 12 A = three glow plugs defective
- 0 A = all glow plugs defective

The current figures can only be obtained with a battery voltage of not less than 11.5 V.

- Remove wire and bus bar for glow plugs.

28-2

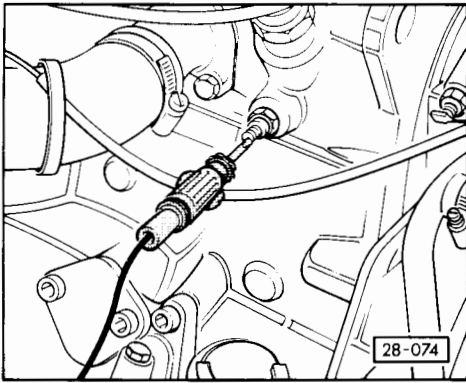

- ◀ – Connect diode test lamp V.A.G 1527 to battery (+) and then to each glow plug in turn.

LED lights up: Glow plug OK.
 LED does light up: Renew glow plug
 (tightening torque:
 25 Nm)

Notes:

- The tightening torque of 25 Nm must not be exceeded, otherwise the circular gap between electrode and body threaded part will be squeezed together. This can cause the glow plug to fail prematurely.
- If no fault is found but the engine is still hard to start, the glow plugs should be visually examined (injectors removed) while glowing.

28-3

Glow plugs with burnt electrodes

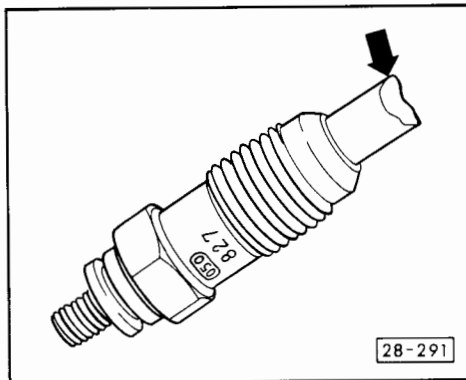

- ◀ Burnt electrodes in glow plugs are frequently caused by faulty injectors. Damage of this nature is not due to faults in or on the glow plugs.

When damage of this nature is found – arrow – it is not sufficient to merely renew the glow plug. The injectors must also be tested for breaking pressures and leakage – see Repair Group 23.

28-4